



product
name

clio

SKU: WBCLIO16

dimensions 16" x 16" x 4-3/4"

available in 30+ colors

example
installation

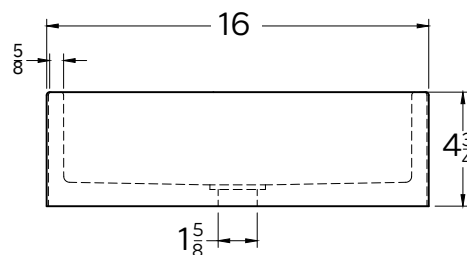
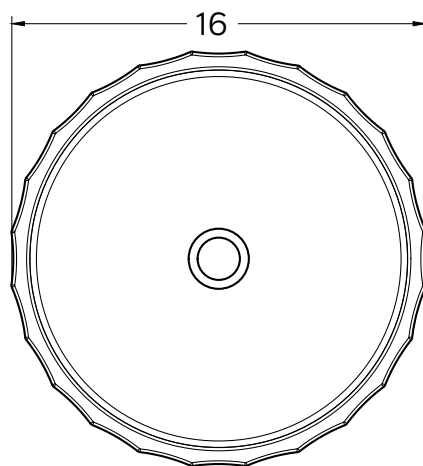
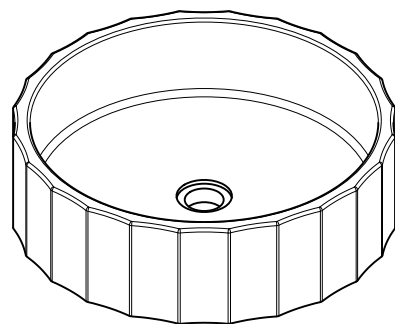

details MATERIAL: ultra high performance concrete
WEIGHT: 22 lbs
DIMENSIONS: 16" x 16" x 4-3/4"
DRAIN: do not exceed 1-1/2" drain diameter
WARRANTY: 1 year manufacturers warranty
DRAIN HOLE: 1-5/8"
WALL THICKNESS: 1/2"
OPTIONS: surface mount / stand