



product
name

lily

SKU: WBLILY16

dimensions **16" x 16" x 3 1/2"**

available in 30+ colors

sample
installation

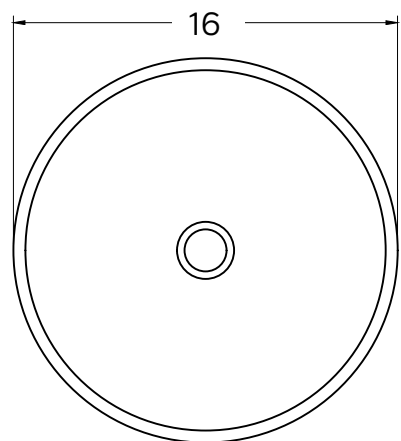
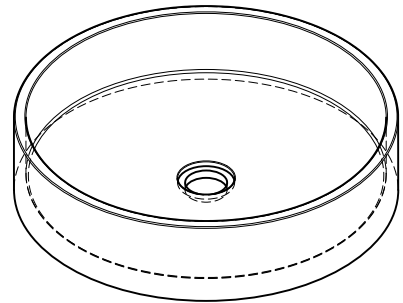

details **MATERIAL:** ultra high performance concrete
WEIGHT: 18 lbs
DIMENSIONS: 16" x 16" x 3 1/2"
DRAIN: do not exceed 1-1/2" drain diameter
WARRANTY: 1 year manufacturers warranty
DRAIN HOLE: 1-5/8"
WALL THICKNESS: 1/2"
OPTIONS: surface mount / stand

