



product
name

lily sq

SKU: WBLILS16

dimensions 16" x 16" x 3-1/2"

available in 30+ colors

example
installation

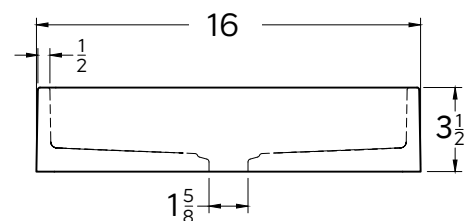
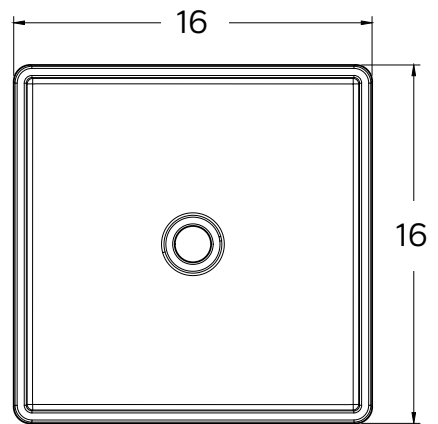
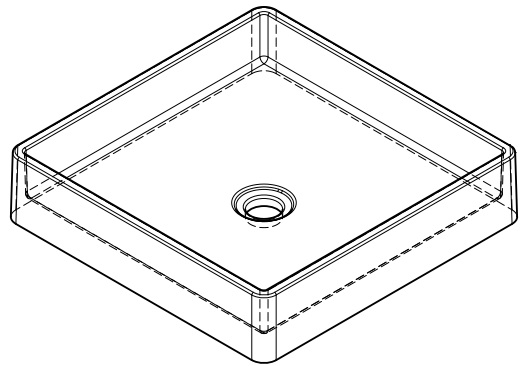
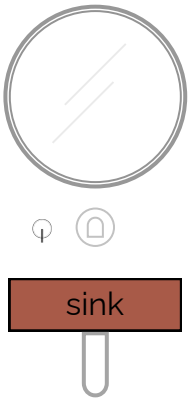

details MATERIAL: ultra high performance concrete
WEIGHT: 22 lbs
DIMENSIONS: 16" x 16" x 3-1/2"
DRAIN: do not exceed 1-1/2" drain diameter
WARRANTY: 1 year manufacturers warranty
DRAIN HOLE: 1-5/8"
WALL THICKNESS: 1/2"
OPTIONS: surface mount / stand
WALL HANG: mount before tiling - to timber frame
or masonry wall.