

product name

# marcus

SKU: VSMA16

dimensions

32" x 16" x 16"

available in 8 colors



Side

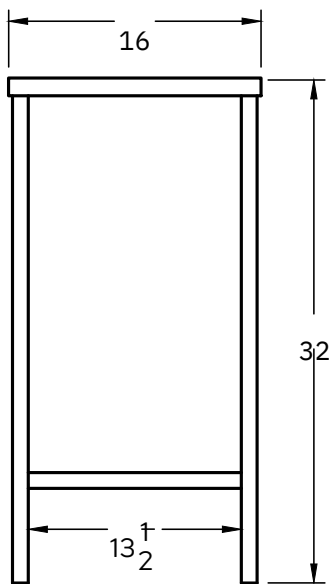

Top

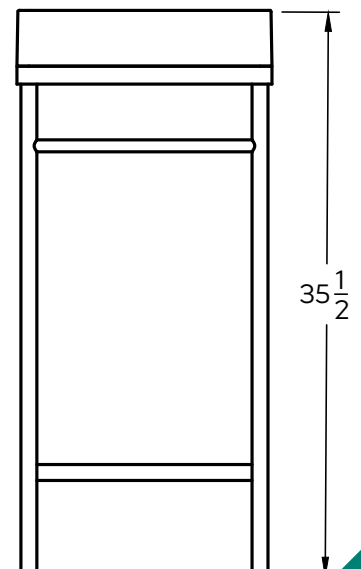
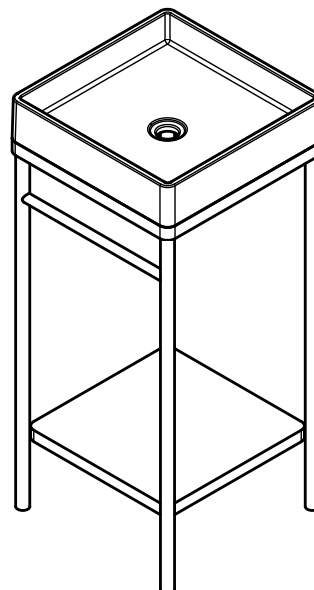
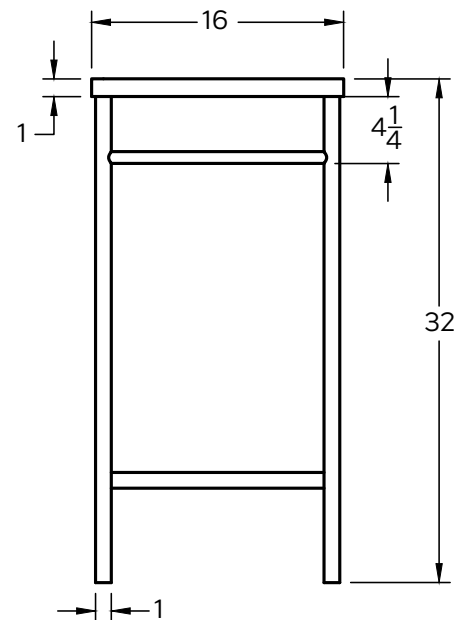
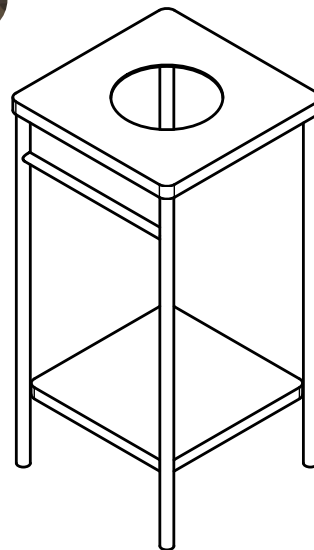
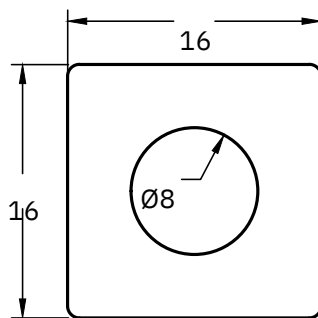

details MATERIAL: powder-coated mild steel  
 WEIGHT: 28 lbs  
 DIMENSIONS: 32" x 16" x 16"  
 PAIRS WITH: lily sq (WBLILS16)  
 WARRANTY: 1 year manufacturers warranty  
 COLOR OPTIONS: onyx, blanco, tungsten, emerald, sapphire, crimson, marigold, sunburst